

ECONOSEAL[®]

E-SYSTEM 2000



Automatic horizontal cartoner for erecting, loading and closing end load cartons

Features

- Sanitary construction (essentially stainless steel)
- Intermittent motion
- Up to 1500 cartons per hour (depending on carton styles and other factors)
- PLC Controls
- Compact 78 x 32" (1980 x 813mm)
- Accommodates glue sealing, tuck closure or hot air closure - Paperboard or corrugated

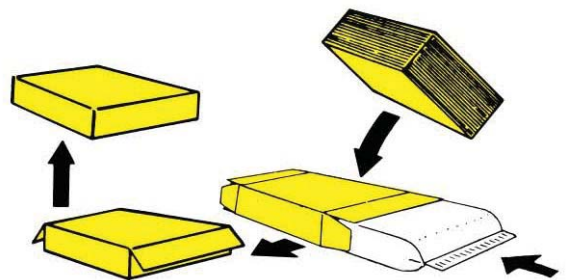

E-System 2000 - Method of operation

1. End load carton is removed from a supply magazine via vacuum system
2. Carton is erected at a single product load station
3. Product is manually or automatically (optional) horizontally loaded into carton
4. Loaded carton is transported to the closing position for tuck closure or sealing with either hot melt glue or hot air
5. A completed carton is then automatically delivered from the machine to a convenient working height

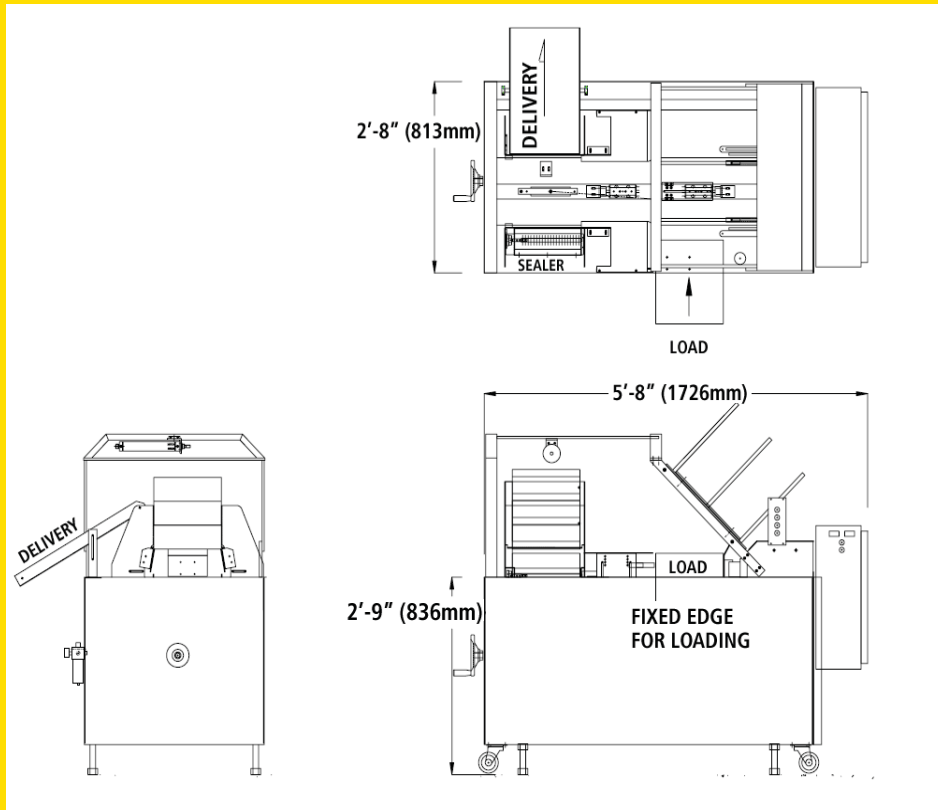

E-System 2000 - ENGINEERING DETAILS

Size Range: (Carton Size)
 Min 1" x 3/4" x 2 1/2"
 (25 x 19 x 64mm)
 Max 12" x 4" x 12"
 (305 x 102 x 305mm)

Air: 80 psi (6,6 bar)
 Volume consumption
 approximately 3.2 CFM
 15.8 SCFM (30 Liters/min)

Speed: Up to 1500 cartons per hour
 depending on carton style,
 and other factors.

Shipping: Normally less than 1300 lbs
 (590 kg)

Electrical: 220 volts, 50/60 Hz,
 Single Phase

All dimensions are approximate and subject to
 change. Machines can be quoted to handle cartons
 outside of range listed above upon request.



72 Pacella Park Drive, Randolph, MA 02368
 Telephone: +1 (781) 986-7500 Fax: +1 (781) 986-1553
 www.econocorp.com e-mail: info@econocorp.com

